

## 12F31

単位重量 : 0.491kg/m

1:1.5

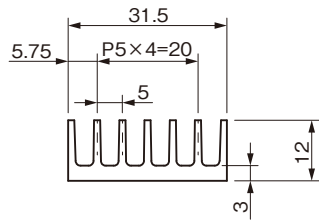

L寸	熱抵抗 (°C/W)
L50	12.69
L100	7.33
L150	5.28

— L=50  
— L=100  
— L=150

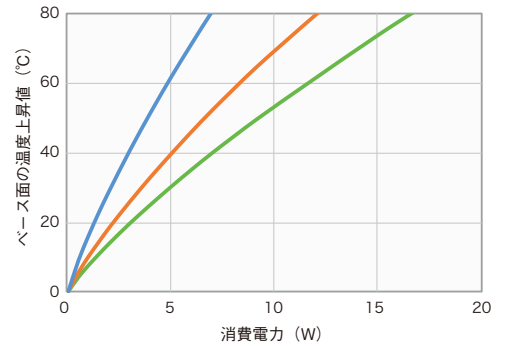

## 12F46

単位重量 : 0.715kg/m

1:1.5

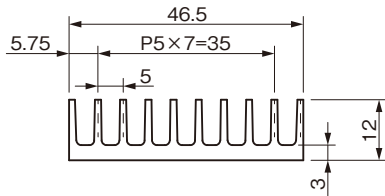

L寸	熱抵抗 (°C/W)
L50	8.40
L100	4.99
L150	3.52

— L=50  
— L=100  
— L=150

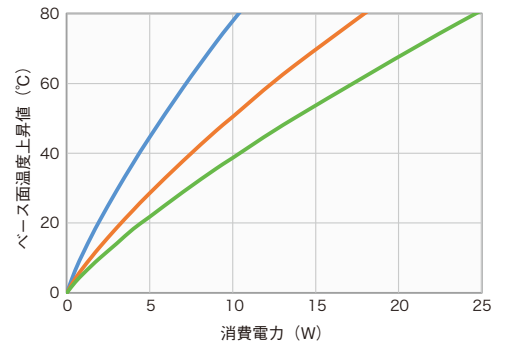

## 12F51

単位重量 : 0.789kg/m

1:1.5

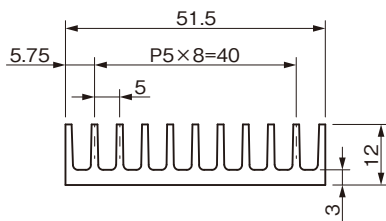

L寸	熱抵抗 (°C/W)
L50	7.58
L100	4.43
L150	3.18

— L=50  
— L=100  
— L=150

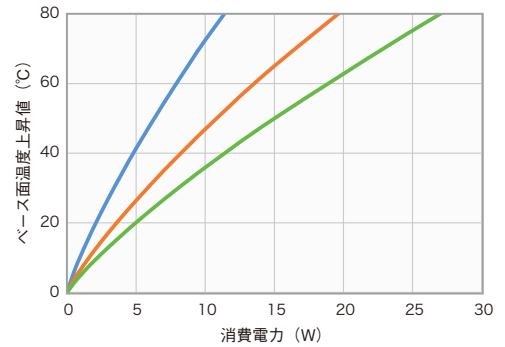

## 12F66

単位重量 : 1.012kg/m

1:1.5

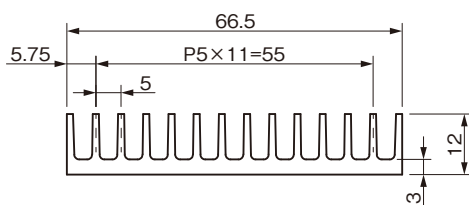

L寸	熱抵抗 (°C/W)
L50	6.02
L100	3.52
L150	2.54

— L=50  
— L=100  
— L=150

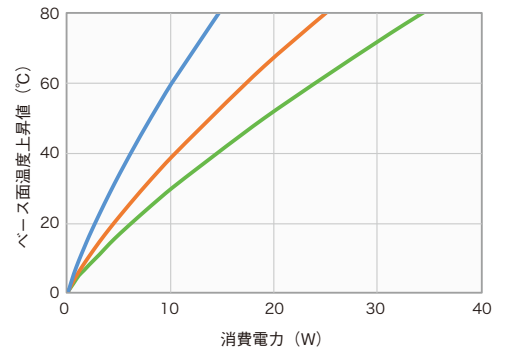

## 12F101

単位重量：1.533kg/m

1:1.8

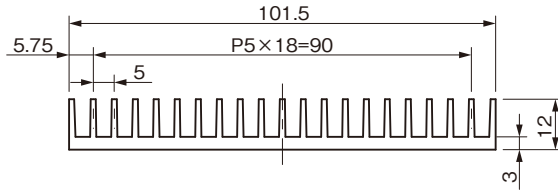

L寸	熱抵抗 (°C/W)
L50	4.05
L100	2.38
L150	1.72

— L=50  
— L=100  
— L=150

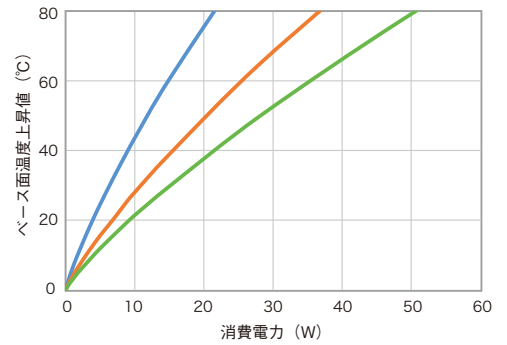

## 12F151

単位重量：2.425kg/m

1:1.8

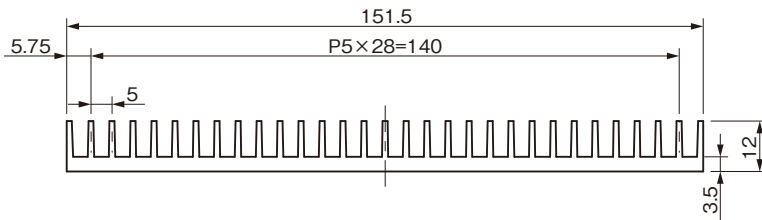

L寸	熱抵抗 (°C/W)
L50	2.76
L100	1.62
L150	1.18

— L=50  
— L=100  
— L=150

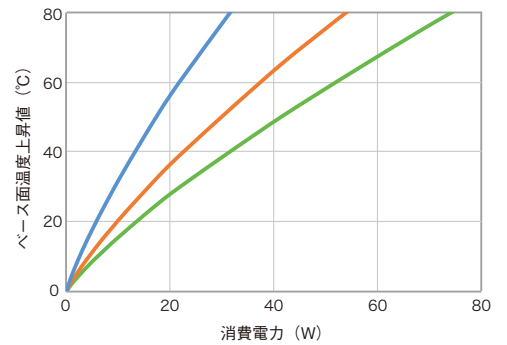

## 17F50A

単位重量：1.005kg/m

1:1.5

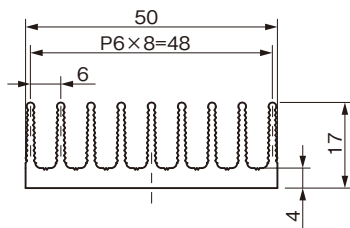

L寸	熱抵抗 (°C/W)
L50	6.80
L100	4.02
L150	2.90

— L=50  
— L=100  
— L=150

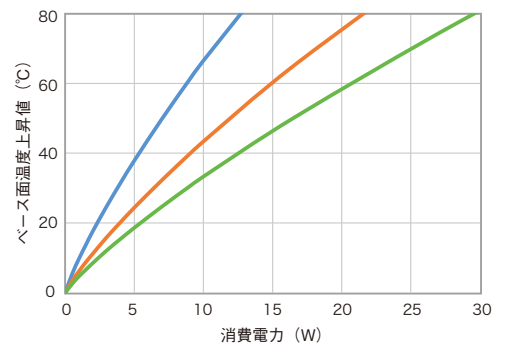

ローレット付

## 17F50B

単位重量：1.109kg/m

1:1.5

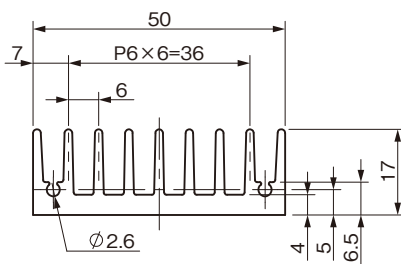

L寸	熱抵抗 (°C/W)
L50	6.80
L100	4.02
L150	2.90

— L=50  
— L=100  
— L=150

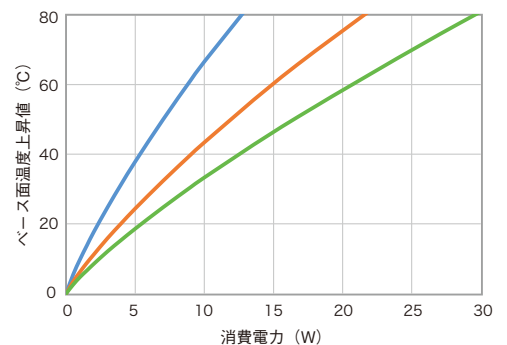

## 17F98

単位重量：1.950kg/m

1:1.8

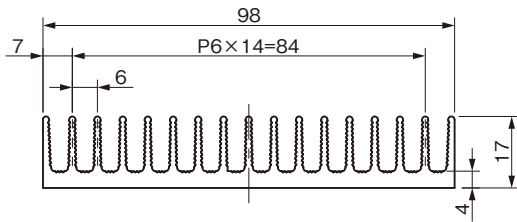

ローレット付

L寸	熱抵抗 (°C/W)
L50	3.71
L100	2.20
L150	1.59

— L=50  
— L=100  
— L=150

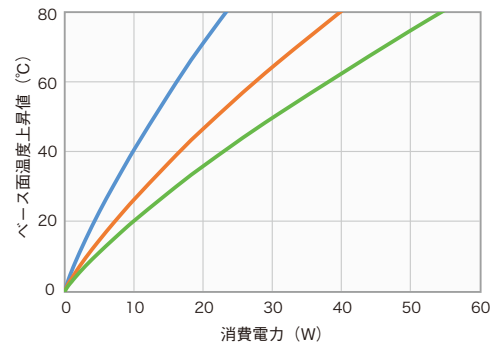

## 17F122

単位重量：2.410kg/m

1:1.8

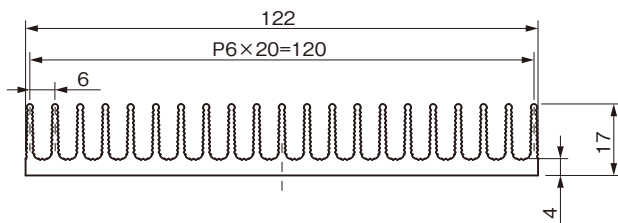

ローレット付

L寸	熱抵抗 (°C/W)
L50	3.01
L100	1.78
L150	1.30

— L=50  
— L=100  
— L=150

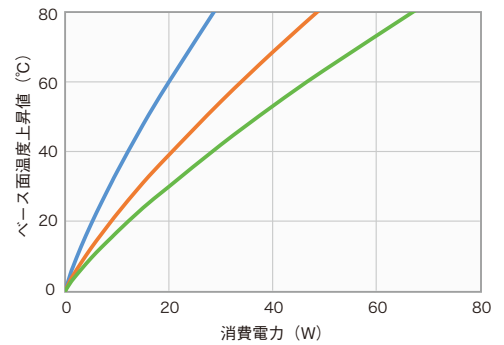

## 17F146

単位重量：2.870kg/m

1:1.8

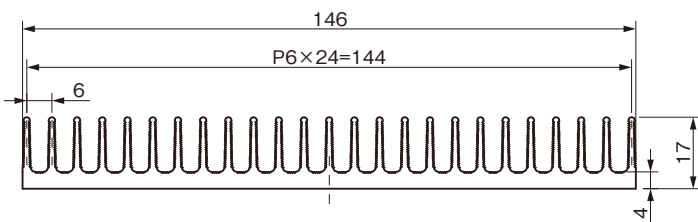

ローレット付

L寸	熱抵抗 (°C/W)
L50	2.53
L100	1.51
L150	1.10

— L=50  
— L=100  
— L=150

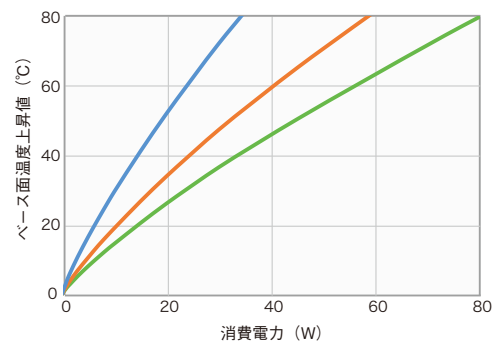

## 17F200

単位重量：4.247kg/m

1:2.25

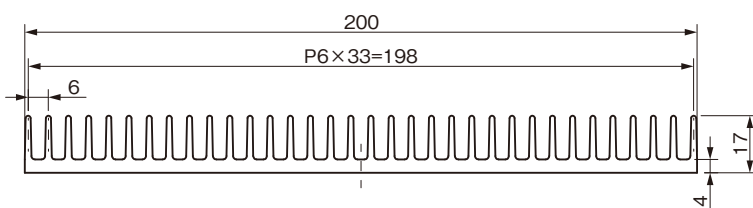

L寸	熱抵抗 (°C/W)
L=50	1.88
L=100	1.12
L=150	0.82

— L=50  
— L=100  
— L=150

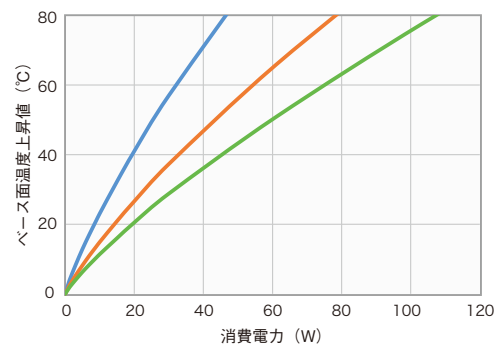

## 20F183

単位重量：4.957kg/m

1:2

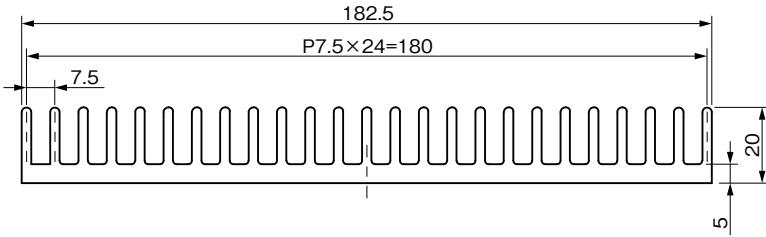

L寸	熱抵抗 (°C/W)
L50	1.69
L100	1.23
L150	0.90

— L=50  
— L=100  
— L=150

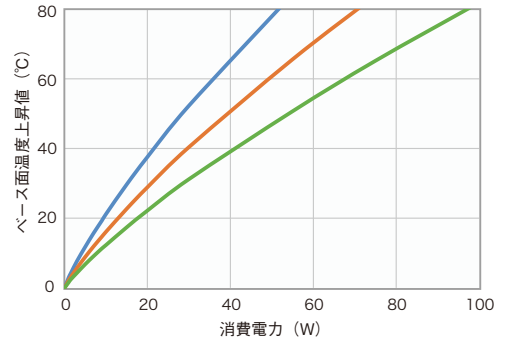

## 21F50

単位重量：1.513kg/m

1:1.8

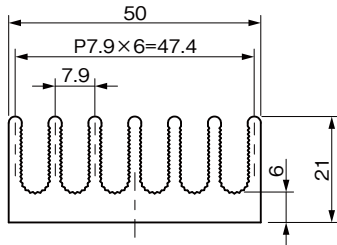

L寸	熱抵抗 (°C/W)
L50	5.55
L100	4.04
L150	2.96

— L=50  
— L=100  
— L=150

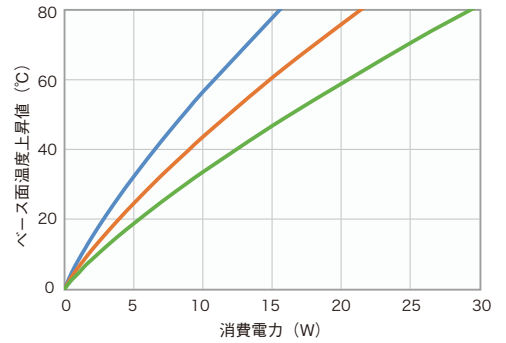

ローレット付

## 21F74

単位重量：2.180kg/m

1:1.8

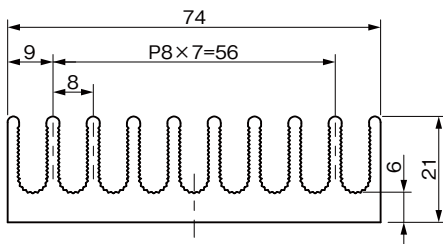

L寸	熱抵抗 (°C/W)
L50	4.01
L100	2.88
L150	2.09

— L=50  
— L=100  
— L=150

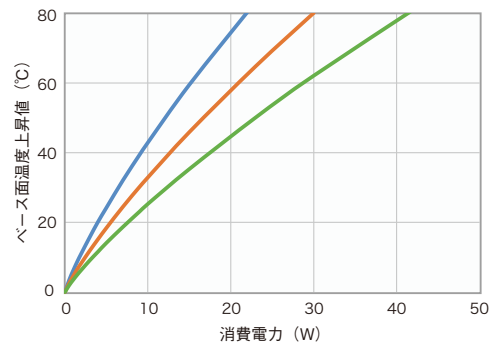

ローレット付

## 21F98

単位重量：2.895kg/m

1:1.8

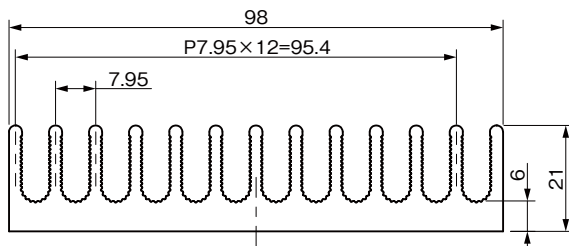

L寸	熱抵抗 (°C/W)
L50	3.06
L100	2.24
L150	1.63

— L=50  
— L=100  
— L=150

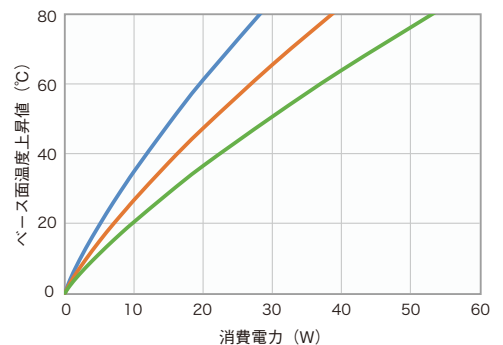

ローレット付

## 21F106

単位重量 : 3.133kg/m

1:1.8

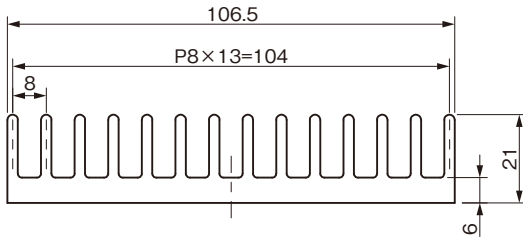

L寸	熱抵抗 (°C/W)
L50	2.89
L100	2.08
L150	1.51

— L=50  
— L=100  
— L=150

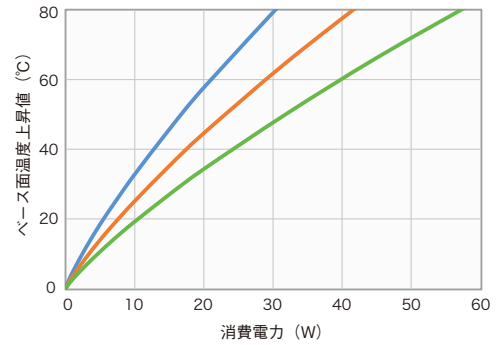

## 21F130

単位重量 : 3.793kg/m

1:1.8

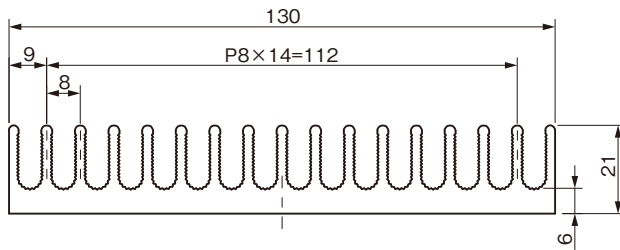

L寸	熱抵抗 (°C/W)
L50	2.37
L100	1.72
L150	1.25

— L=50  
— L=100  
— L=150

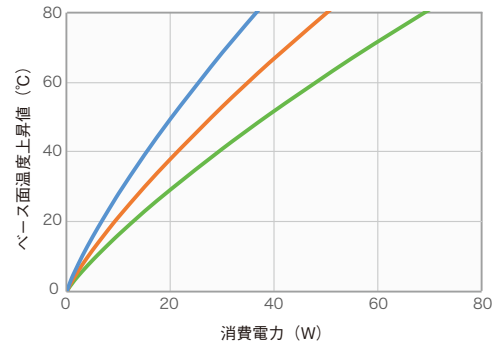

ローレット付

## 21F154

単位重量 : 4.480kg/m

1:1.8

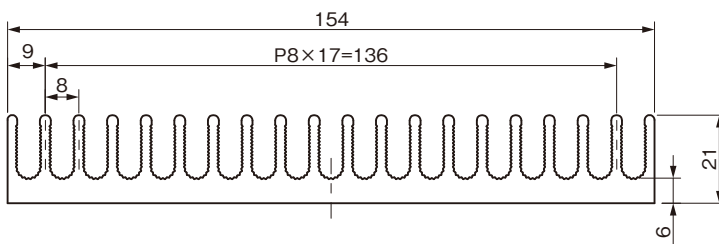

L寸	熱抵抗 (°C/W)
L50	2.02
L100	1.48
L150	1.08

— L=50  
— L=100  
— L=150

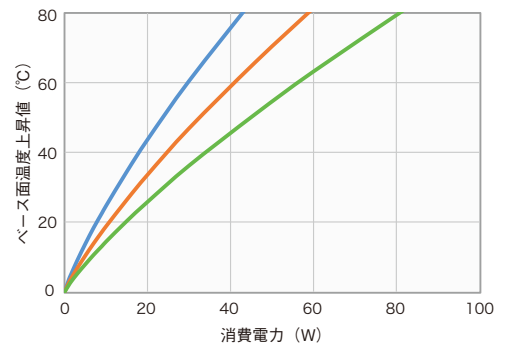

ローレット付

## 21F170

単位重量 : 3.578kg/m

1:1.8

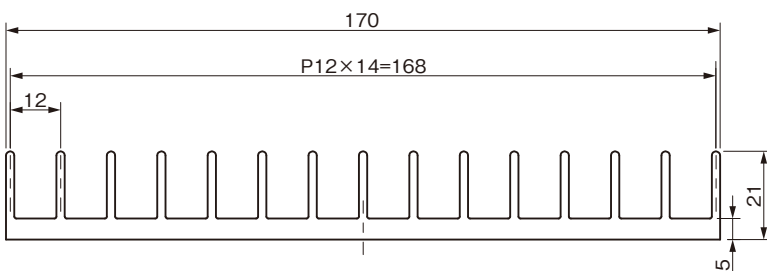

L寸	熱抵抗 (°C/W)
L50	2.09
L100	1.25
L150	1.11

— L=50  
— L=100  
— L=150

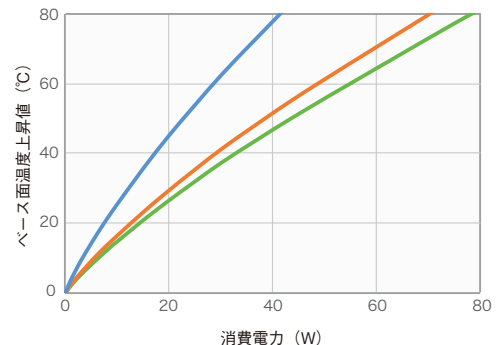

## 21F210

単位重量：6.168kg/m

1:2.5

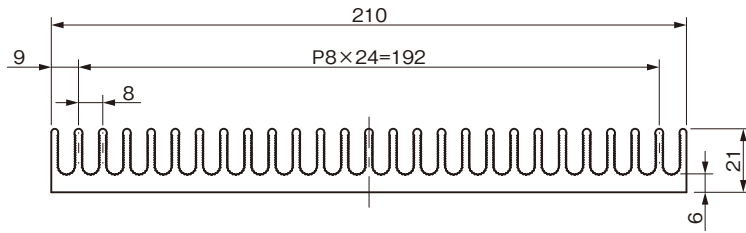

ローレット付

L寸	熱抵抗 (°C/W)
L=50	1.51
L=100	1.09
L=150	0.80

— L=50  
— L=100  
— L=150

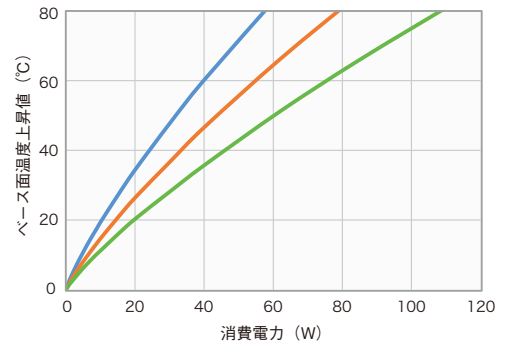

## 21F230

単位重量：4.840kg/m

1:2.5

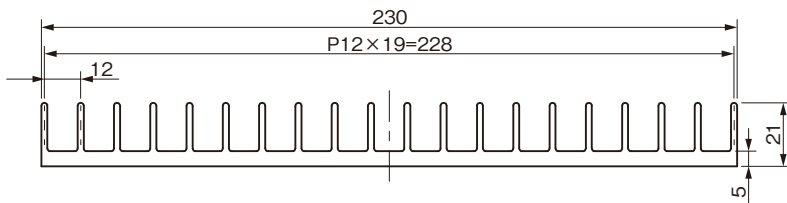

L寸	熱抵抗 (°C/W)
L=50	1.58
L=100	0.94
L=150	0.84

— L=50  
— L=100  
— L=150

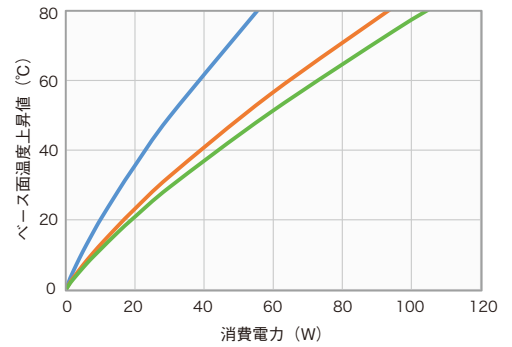

## 21F298

単位重量：8.751kg/m

1:3.25

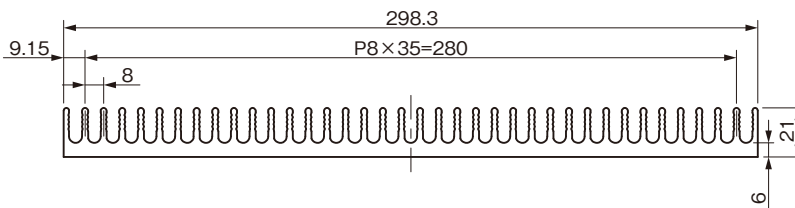

ローレット付

L寸	熱抵抗 (°C/W)
L=50	1.07
L=100	0.79
L=150	0.58

— L=50  
— L=100  
— L=150

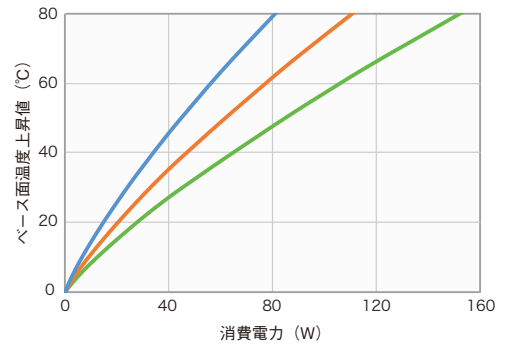

## 21F304

単位重量：8.829kg/m

1:3.5

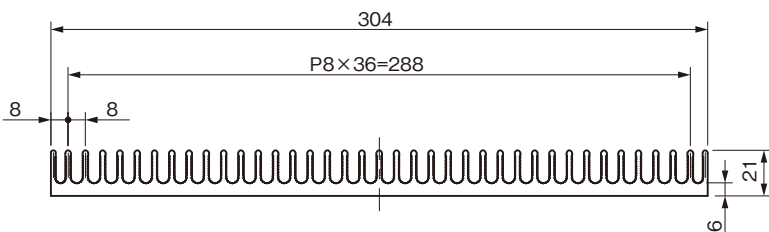

ローレット付

L寸	熱抵抗 (°C/W)
L=50	1.05
L=100	0.76
L=150	0.55

— L=50  
— L=100  
— L=150

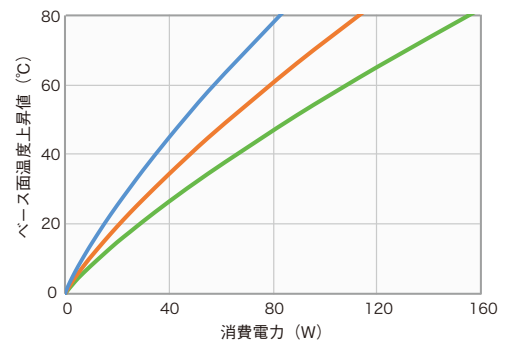

## 24F84

単位重量：2.173kg/m

1:1.8

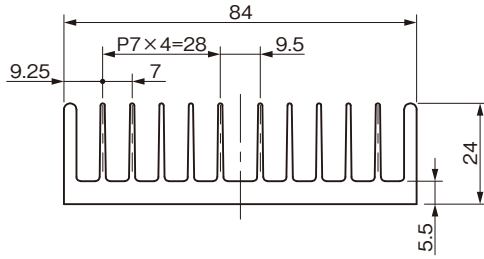

L寸	熱抵抗 (°C/W)
L50	3.12
L100	2.27
L150	1.66

— L=50  
— L=100  
— L=150

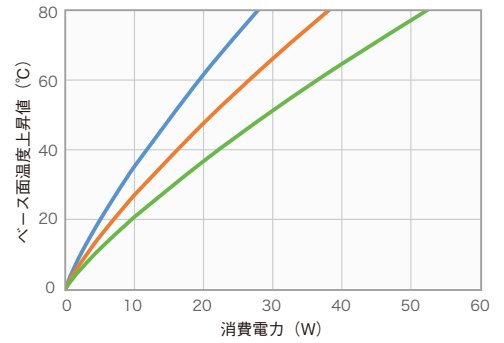

## 25F150

単位重量：3.209kg/m

1:2

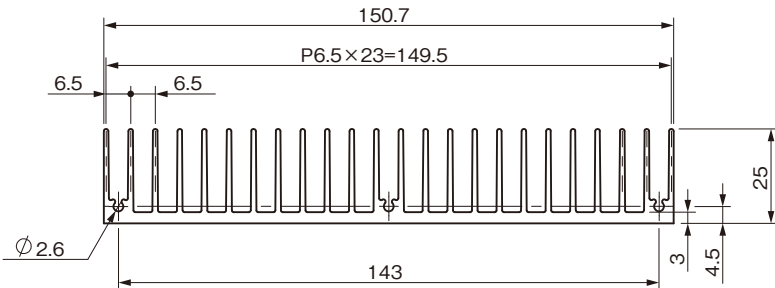

L寸	熱抵抗 (°C/W)
L=50	1.52
L=100	1.12
L=150	0.83

— L=50  
— L=100  
— L=150

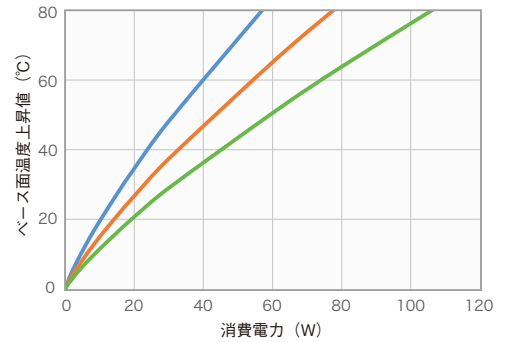

## 25F294

単位重量：6.539kg/m

1:3.5

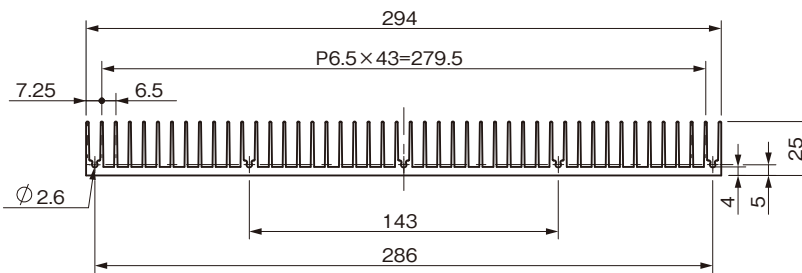

L寸	熱抵抗 (°C/W)
L=50	0.83
L=100	0.61
L=150	0.45

— L=50  
— L=100  
— L=150

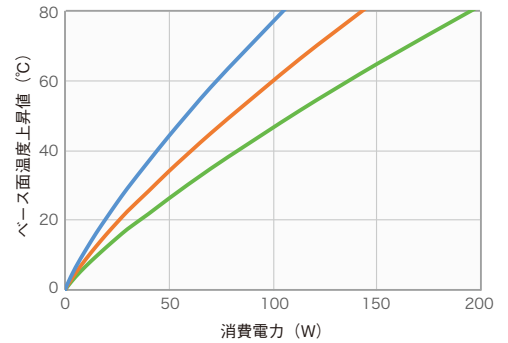

## 30F34

単位重量：0.977kg/m

1:1.8

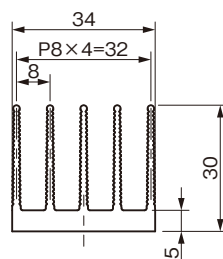

L寸	熱抵抗 (°C/W)
L50	5.68
L100	4.13
L150	3.01

— L=50  
— L=100  
— L=150

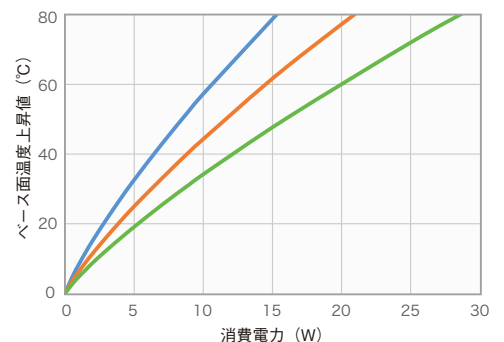

## 30F58

単位重量：1.590kg/m

1:1.8

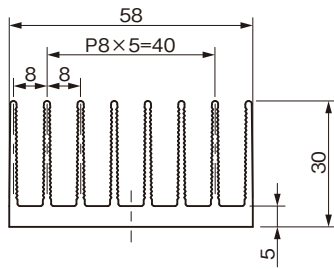

ローレット付

L寸	熱抵抗 (°C/W)
L50	3.65
L100	2.68
L150	1.96

— L=50  
— L=100  
— L=150

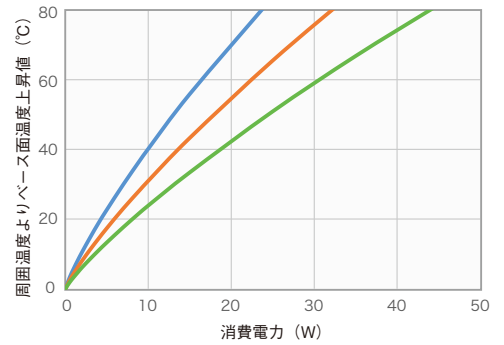

## 30F74

単位重量：2.002kg/m

1:1.8

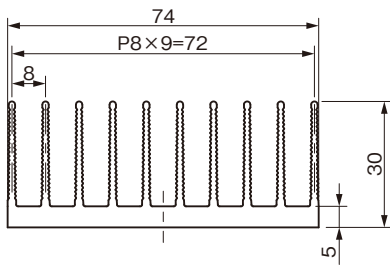

ローレット付

L寸	熱抵抗 (°C/W)
L50	2.97
L100	2.17
L150	1.59

— L=50  
— L=100  
— L=150

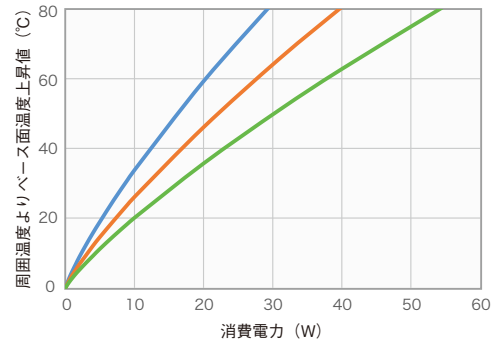

## 30F98

単位重量：2.623kg/m

1:1.8

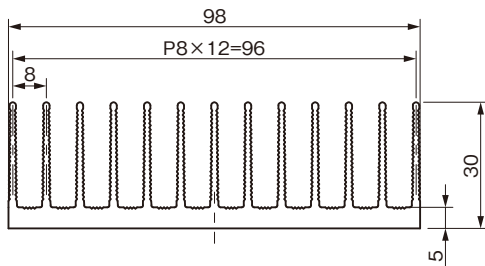

ローレット付

L寸	熱抵抗 (°C/W)
L50	2.30
L100	1.70
L150	1.25

— L=50  
— L=100  
— L=150

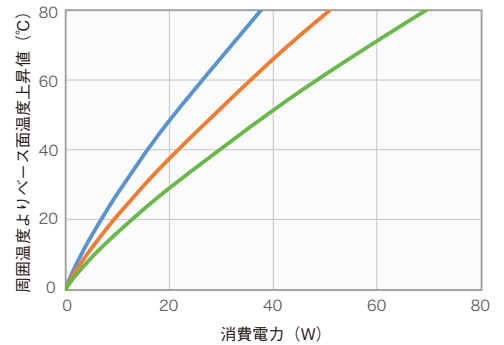

## 30F109

単位重量：2.878kg/m

1:2.25

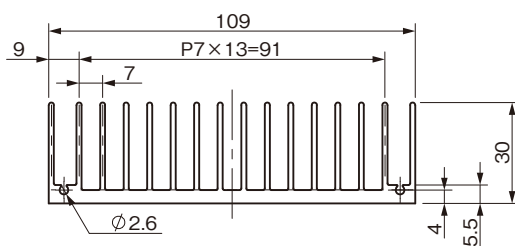

L寸	熱抵抗 (°C/W)
L50	1.93
L100	1.42
L150	1.05

— L=50  
— L=100  
— L=150

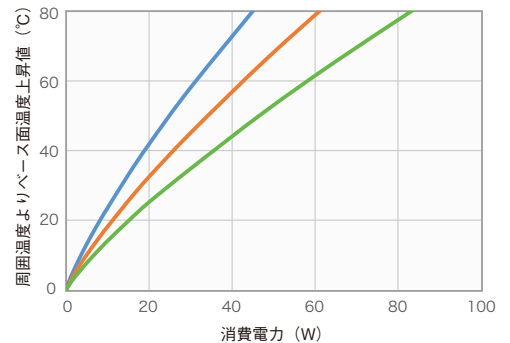



## 30F138

単位重量：3.634kg/m

1:2.25

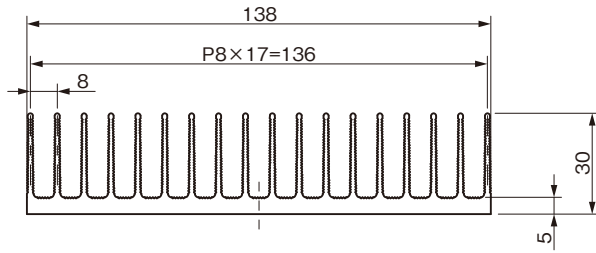

ローレット付

L寸	熱抵抗 (°C/W)
L50	1.68
L100	1.24
L150	0.92

— L=50  
— L=100  
— L=150

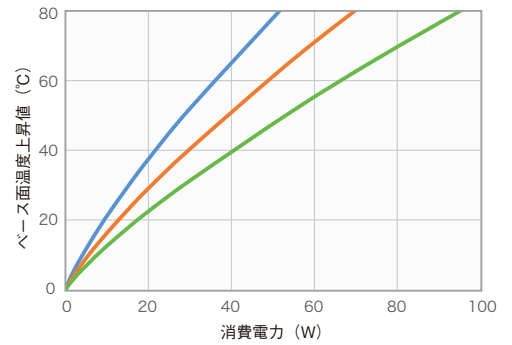

## 30F143

単位重量：4.160kg/m

1:2.25

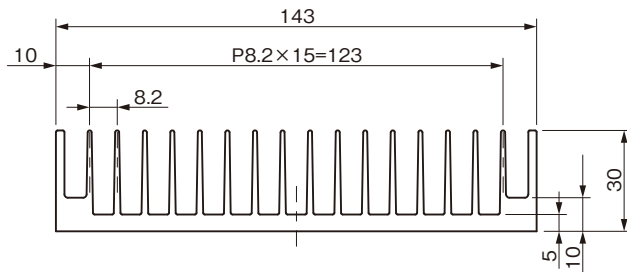

ローレット付

L寸	熱抵抗 (°C/W)
L50	1.66
L100	1.23
L150	0.90

— L=50  
— L=100  
— L=150

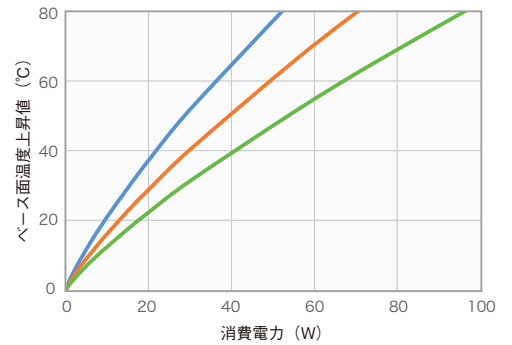

## 30F202

単位重量：5.332kg/m

1:2.25

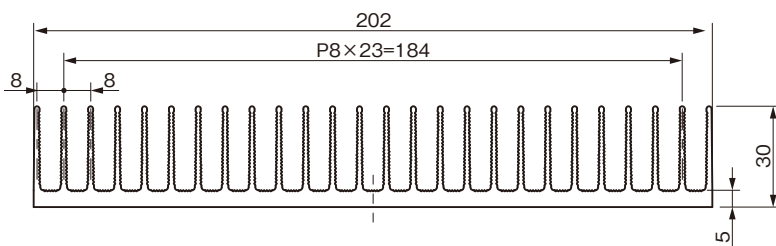

ローレット付

L寸	熱抵抗 (°C/W)
L=50	1.17
L=100	0.87
L=150	0.64

— L=50  
— L=100  
— L=150

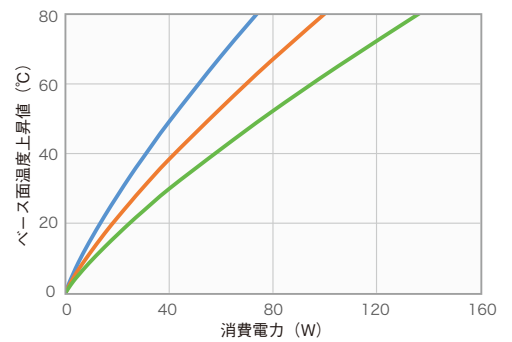

## 30F250

単位重量：6.610kg/m

1:3.25

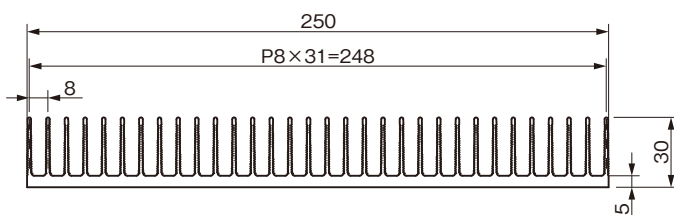

ローレット付

L寸	熱抵抗 (°C/W)
L=50	0.96
L=100	0.71
L=150	0.52

— L=50  
— L=100  
— L=150

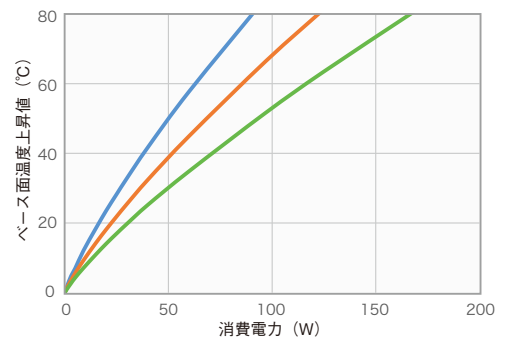

## 30F298

単位重量：9.134kg/m

1:3.25

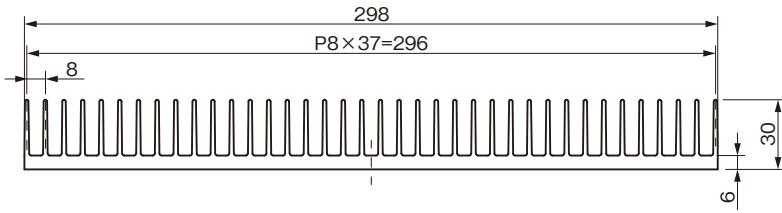

L寸	熱抵抗 (°C/W)
L=50	0.81
L=100	0.61
L=150	0.45

— L=50  
— L=100  
— L=150

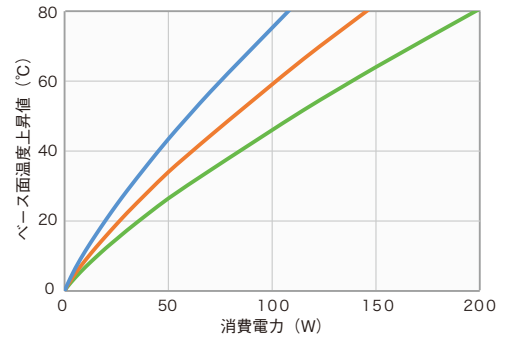

## 32F123

単位重量：4.730kg/m

1:1.8

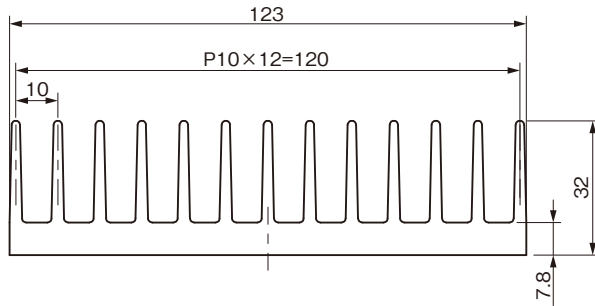

L寸	熱抵抗 (°C/W)
L50	2.09
L100	1.55
L150	1.14

— L=50  
— L=100  
— L=150

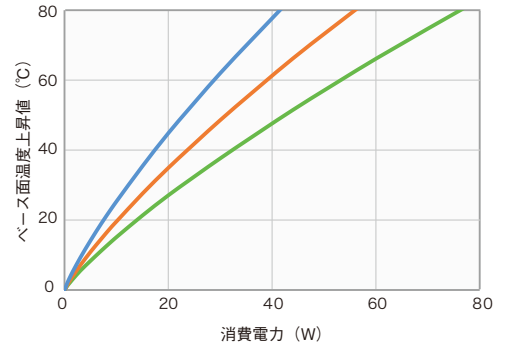

## 33F58

単位重量：1.874kg/m

1:1.8

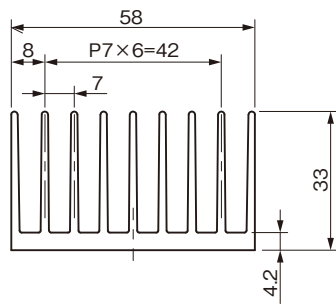

L寸	熱抵抗 (°C/W)
L50	3.13
L100	2.30
L150	1.68

— L=50  
— L=100  
— L=150

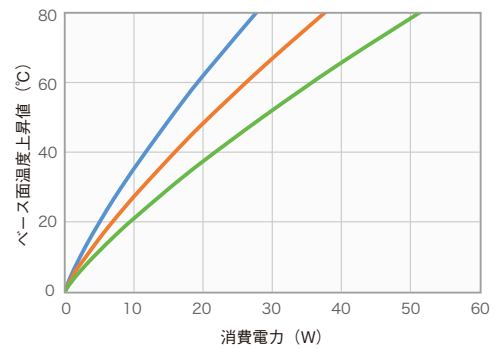

## 33F152

単位重量：4.510kg/m

1:2.75

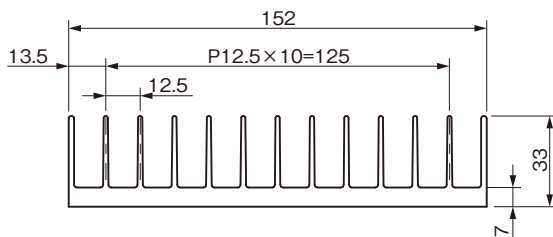

L寸	熱抵抗 (°C/W)
L50	1.82
L100	1.10
L150	1.00

— L=50  
— L=100  
— L=150

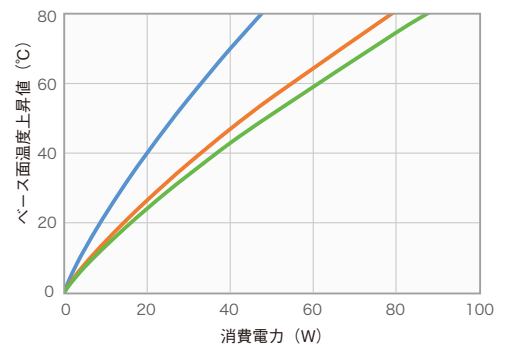

## 33F170

単位重量：3.070kg/m

1:2.75

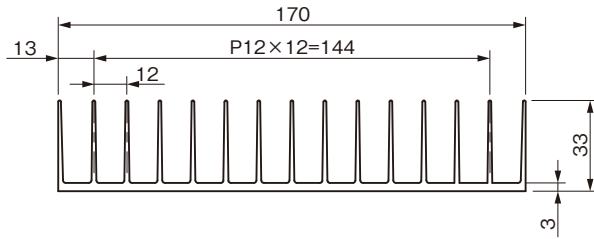

L寸	熱抵抗 (°C/W)
L50	1.52
L100	0.92
L150	0.83

— L=50  
— L=100  
— L=150

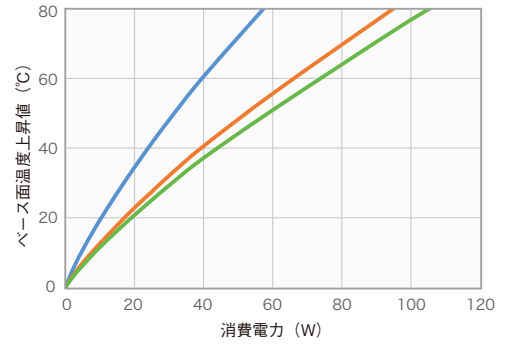

## 33F250

単位重量：8.510kg/m

1:2.75

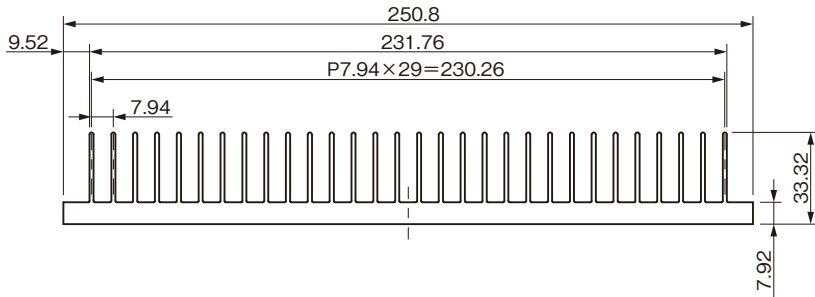

L寸	熱抵抗 (°C/W)
L=50	0.97
L=100	0.72
L=150	0.53

— L=50  
— L=100  
— L=150

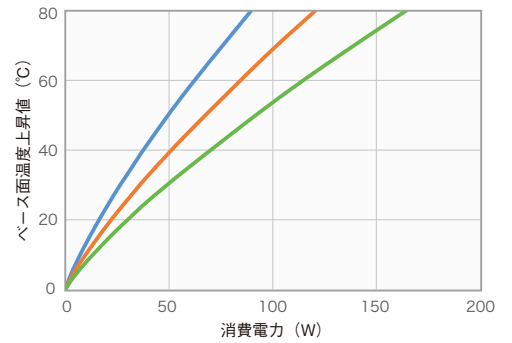

## 35F159

単位重量：3.820kg/m

1:2.25

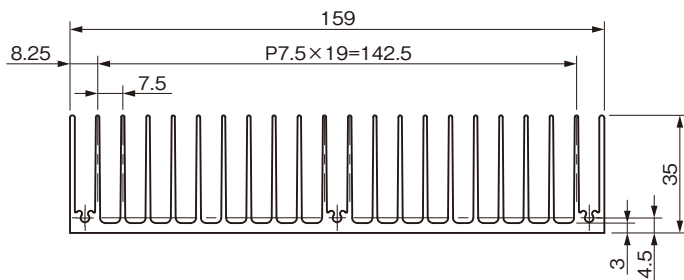

L寸	熱抵抗 (°C/W)
L50	1.21
L100	0.90
L150	0.67

— L=50  
— L=100  
— L=150

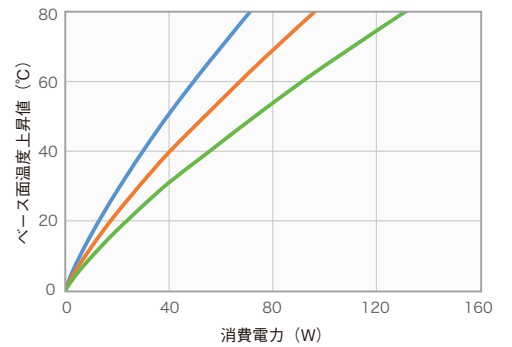

## 40F40

単位重量：1.977kg/m

1:1.8

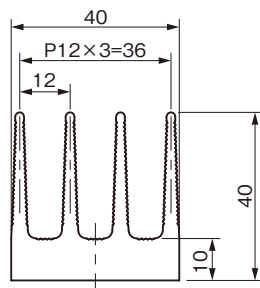

L寸	熱抵抗 (°C/W)
L50	4.98
L100	3.02
L150	2.72

— L=50  
— L=100  
— L=150

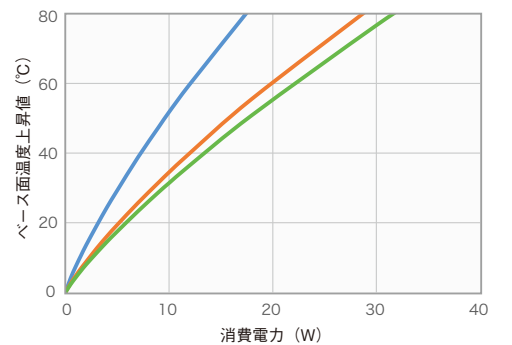

ローレット付

## 40F52

単位重量：2.505kg/m

1:1.8

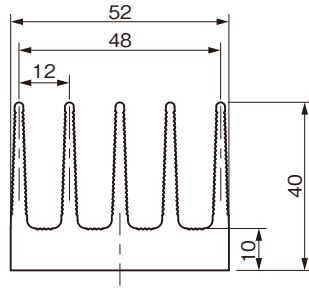

ローレット付

L寸	熱抵抗 (°C/W)
L50	4.09
L100	2.49
L150	2.23

— L=50  
— L=100  
— L=150

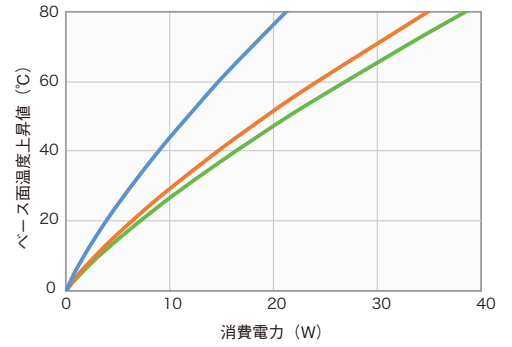

## 40F64

単位重量：2.813kg/m

1:1.8

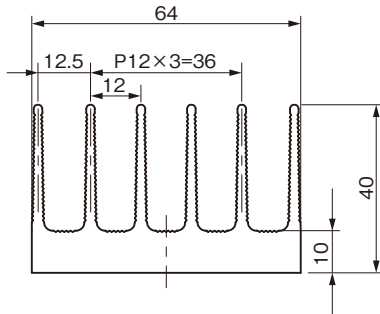

ローレット付

L寸	熱抵抗 (°C/W)
L50	3.45
L100	2.09
L150	1.89

— L=50  
— L=100  
— L=150

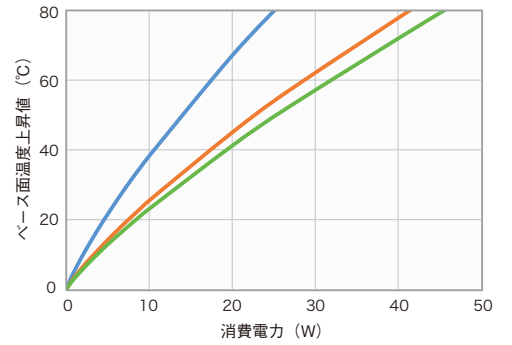

## 40F78

単位重量：3.972kg/m

1:1.8

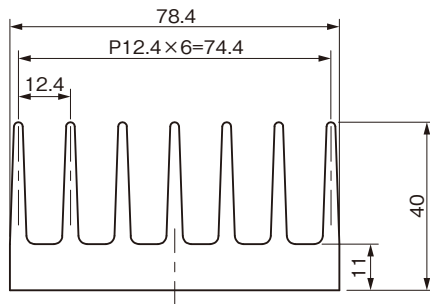

ローレット付

L寸	熱抵抗 (°C/W)
L50	3.01
L100	1.83
L150	1.66

— L=50  
— L=100  
— L=150

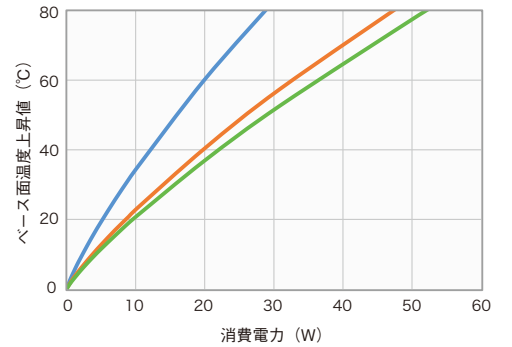

## 40F88

単位重量：3.810kg/m

1:2.25

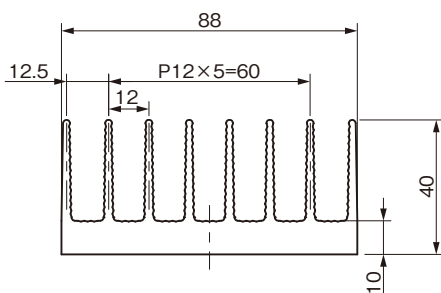

ローレット付

L寸	熱抵抗 (°C/W)
L50	2.63
L100	1.61
L150	1.45

— L=50  
— L=100  
— L=150

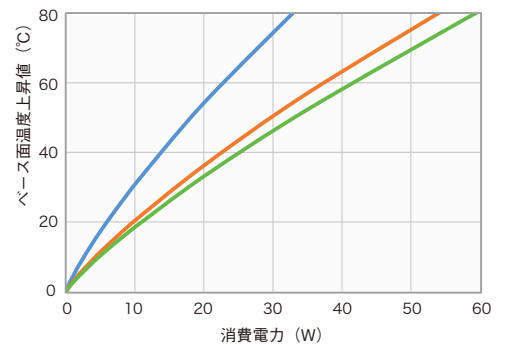

## 40F100

単位重量：4.680kg/m

1:2.25

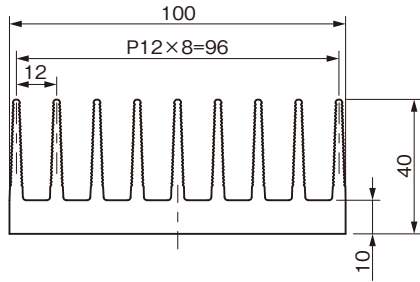

ローレット付

L寸	熱抵抗 (°C/W)
L50	2.38
L100	1.45
L150	1.31

— L=50  
— L=100  
— L=150

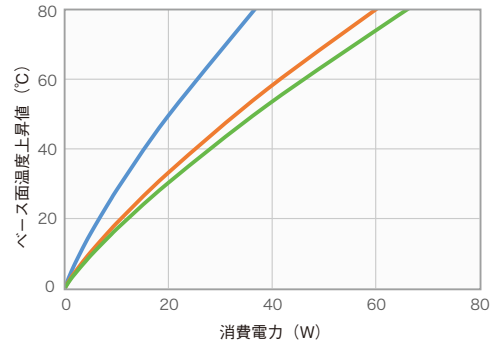

## 40F136

単位重量：5.835kg/m

1:2.25

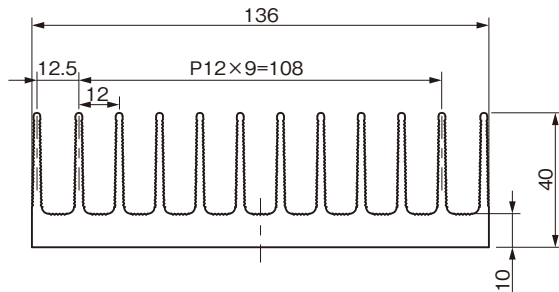

ローレット付

L寸	熱抵抗 (°C/W)
L50	1.80
L100	1.10
L150	1.00

— L=50  
— L=100  
— L=150

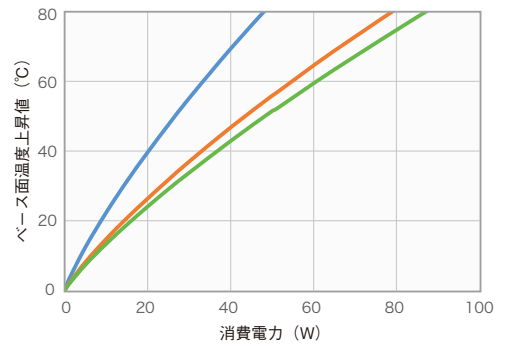

## 40F160

単位重量：7.706kg/m

1:2.25

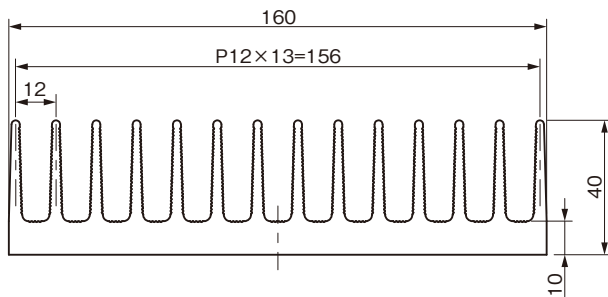

ローレット付

L寸	熱抵抗 (°C/W)
L50	1.55
L100	0.95
L150	0.86

— L=50  
— L=100  
— L=150

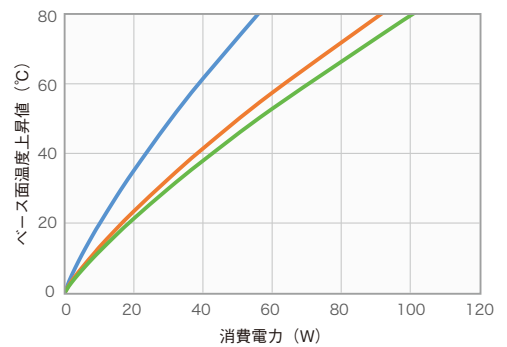

## 40F220

単位重量：10.500kg/m

1:3.5

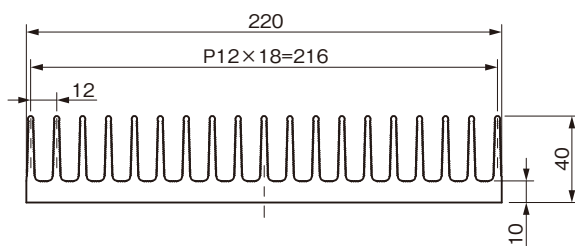

ローレット付

L寸	熱抵抗 (°C/W)
L=50	1.16
L=100	0.71
L=150	0.64

— L=50  
— L=100  
— L=150

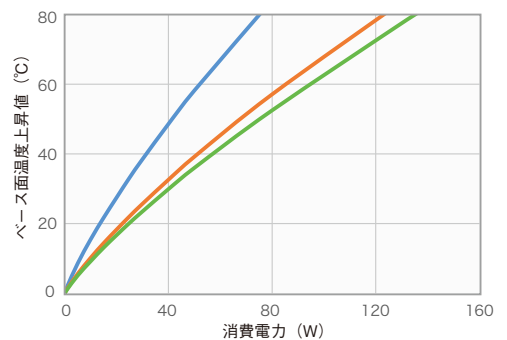

## 40F256

単位重量：10.079kg/m

1:3.5

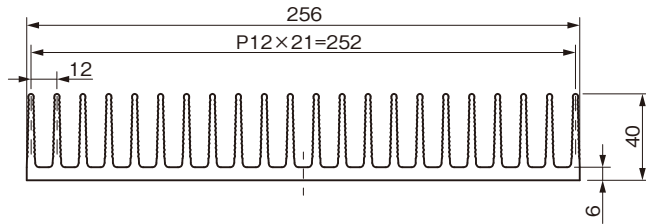

ローレット付

L寸	熱抵抗 (°C/W)
L=50	0.94
L=100	0.58
L=150	0.53

— L=50  
— L=100  
— L=150

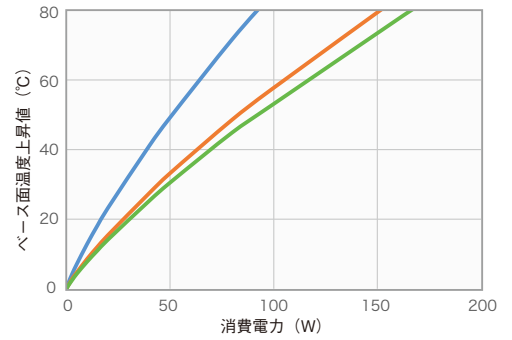

## 40F268

単位重量：12.592kg/m

1:3.5

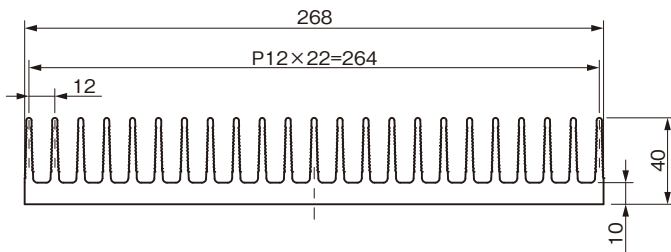

ローレット付

L寸	熱抵抗 (°C/W)
L=50	0.96
L=100	0.59
L=150	0.53

— L=50  
— L=100  
— L=150

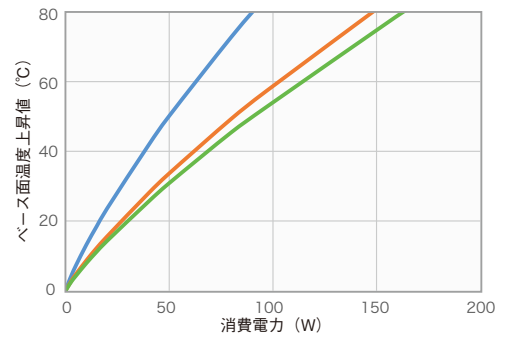

## 40F273

単位重量：10.500kg/m

1:3.5

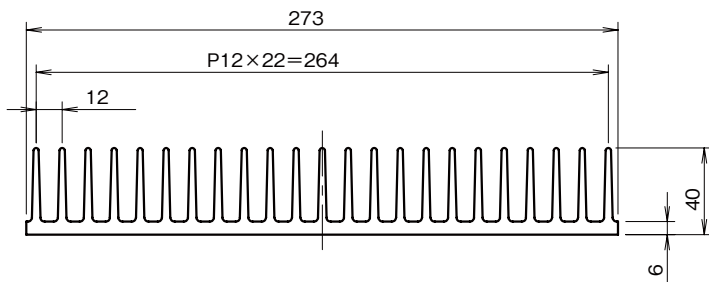

ローレット付

L寸	熱抵抗 (°C/W)
L=50	0.89
L=100	0.54
L=150	0.49

— L=50  
— L=100  
— L=150

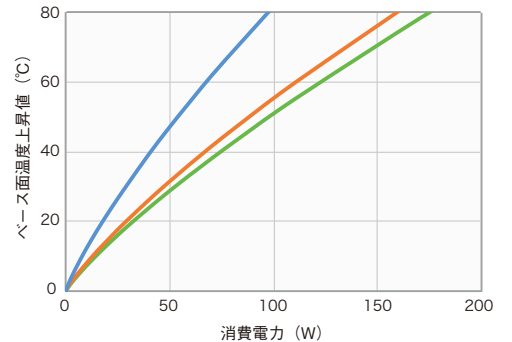

## 40F304

単位重量：11.959kg/m

1:3.5

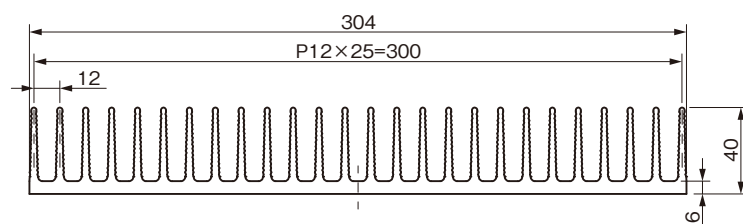

ローレット付

L寸	熱抵抗 (°C/W)
L=50	0.80
L=100	0.49
L=150	0.45

— L=50  
— L=100  
— L=150

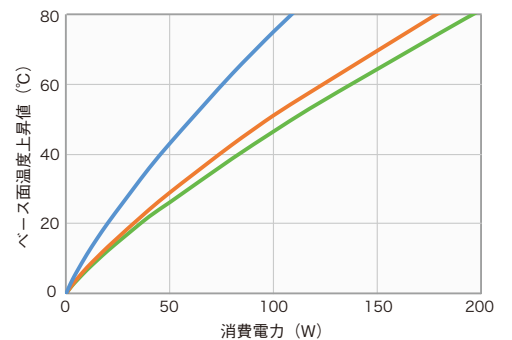

## 48F170

単位重量：5.752kg/m

1:3

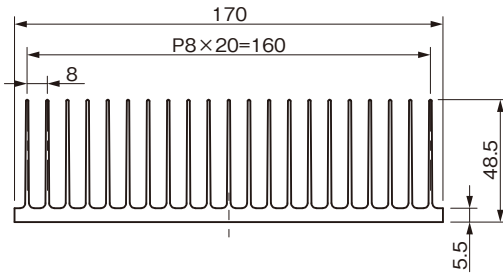

L寸	熱抵抗(°C/W)
L=50	0.97
L=100	0.73
L=150	0.54

— L=50  
— L=100  
— L=150

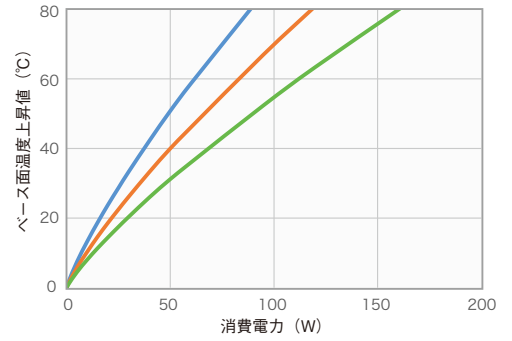

## 50F147

単位重量：7.003kg/m

1:3

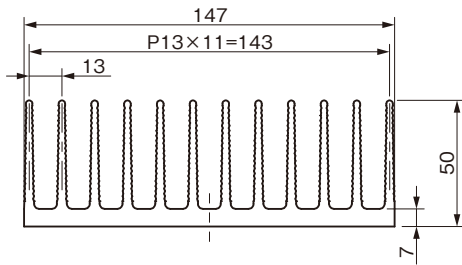

L寸	熱抵抗(°C/W)
L=50	1.38
L=100	0.86
L=150	0.78

— L=50  
— L=100  
— L=150

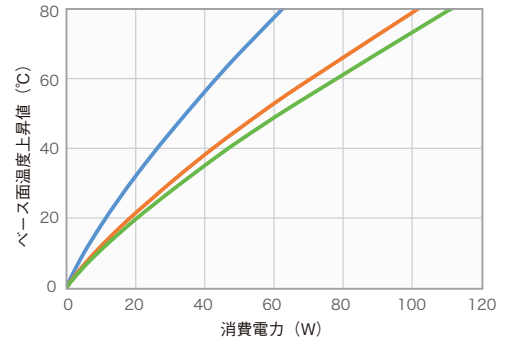

ローレット付

## 50F199

単位重量：9.445kg/m

1:3

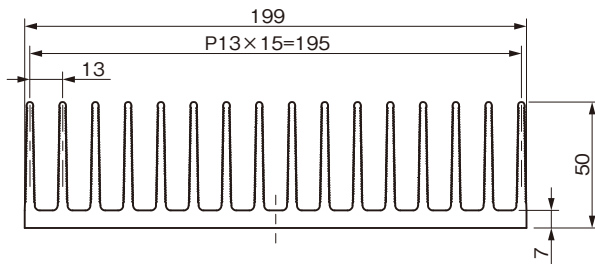

L寸	熱抵抗(°C/W)
L=50	1.04
L=100	0.65
L=150	0.59

— L=50  
— L=100  
— L=150

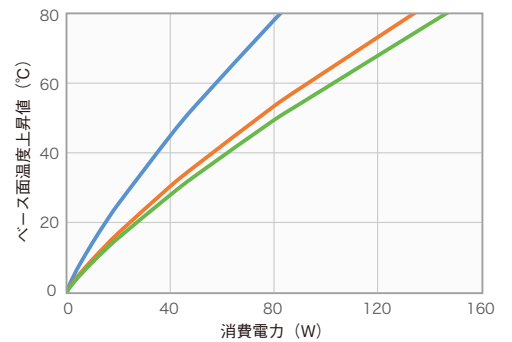

ローレット付

## 51F112

単位重量：3.964kg/m

1:2.25

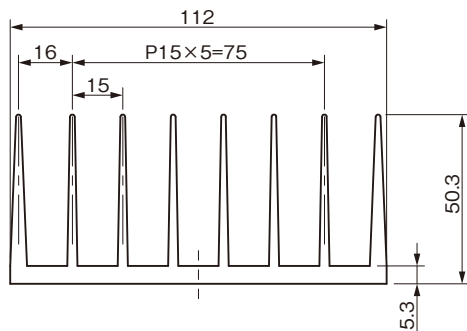

L寸	熱抵抗(°C/W)
L=50	1.88
L=100	1.16
L=150	0.85

— L=50  
— L=100  
— L=150

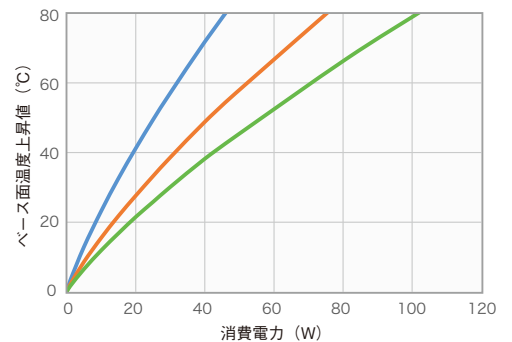

## 51F349

単位重量：17.280kg/m

1:3.75

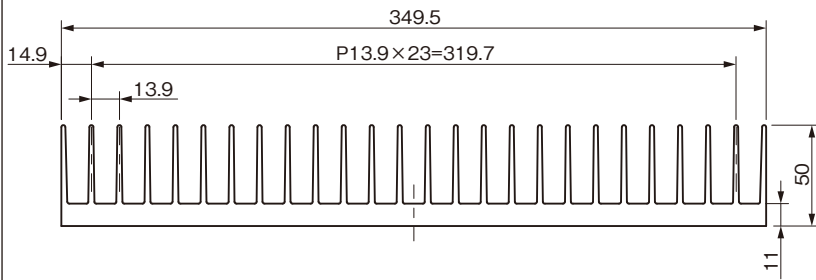

L寸	熱抵抗 (°C/W)
L=50	0.67
L=100	0.42
L=150	0.38

— L=50  
— L=100  
— L=150

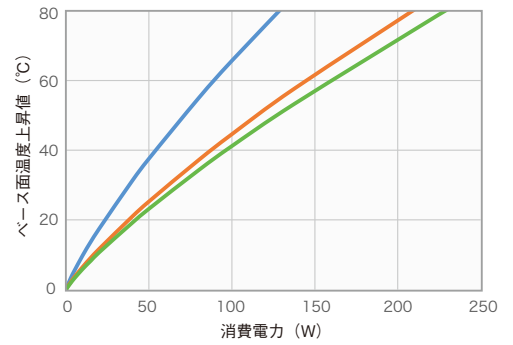

## 60F56

単位重量：3.983kg/m

1:2.25

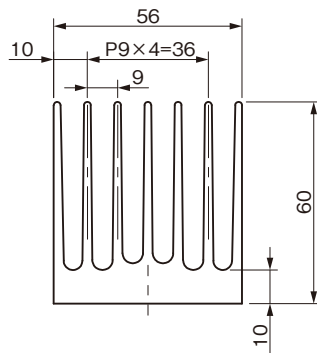

L寸	熱抵抗 (°C/W)
L=50	2.32
L=100	1.73
L=150	1.29

— L=50  
— L=100  
— L=150

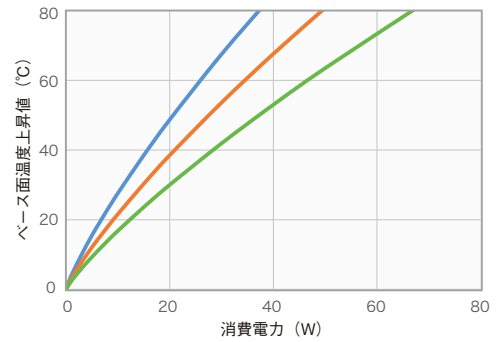

## 60F60

単位重量：4.849kg/m

1:2.25

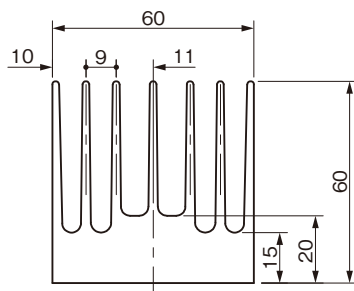

L寸	熱抵抗 (°C/W)
L=50	2.39
L=100	1.81
L=150	1.34

— L=50  
— L=100  
— L=150

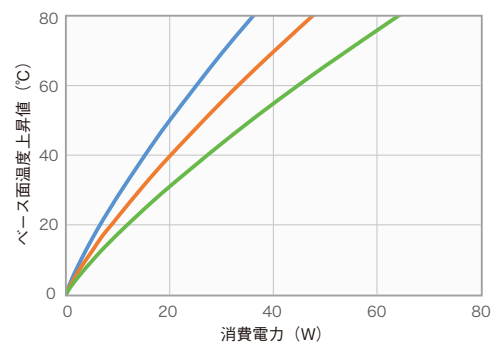

## 60F110

単位重量：8.126kg/m

1:3

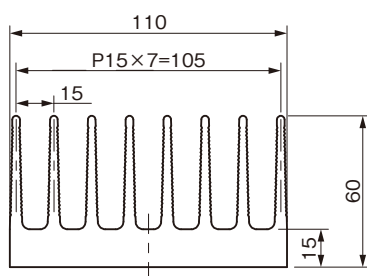

L寸	熱抵抗 (°C/W)
L=50	1.78
L=100	1.11
L=150	1.01

— L=50  
— L=100  
— L=150

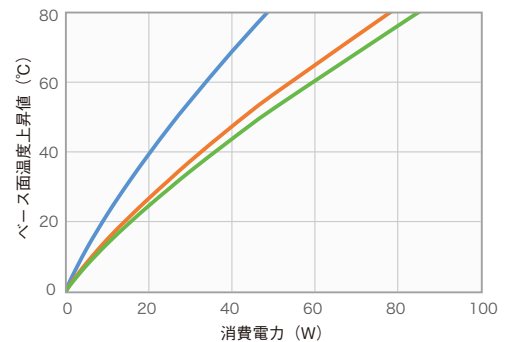

ローレット付



## 60F155

単位重量：11.361kg/m

1:3

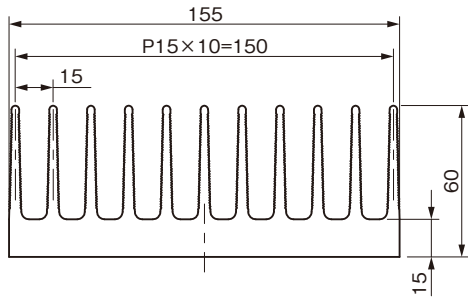

ローレット付

L寸	熱抵抗(°C/W)
L=50	1.33
L=100	0.83
L=150	0.76

— L=50  
— L=100  
— L=150

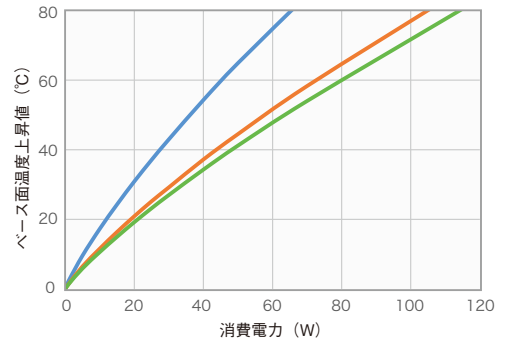

## 60F230

単位重量：16.654kg/m

1:3

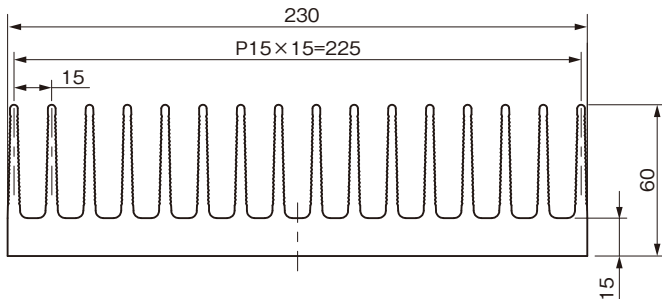

ローレット付

L寸	熱抵抗(°C/W)
L=50	0.93
L=100	0.58
L=150	0.53

— L=50  
— L=100  
— L=150

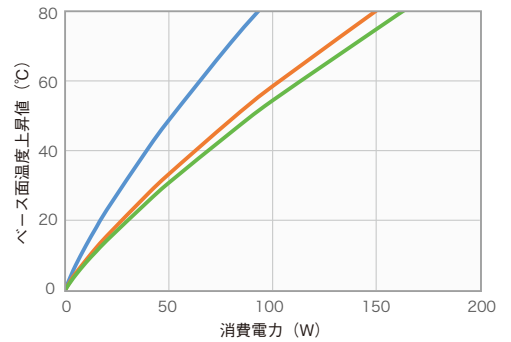

## 60F260

単位重量：15.012kg/m

1:3

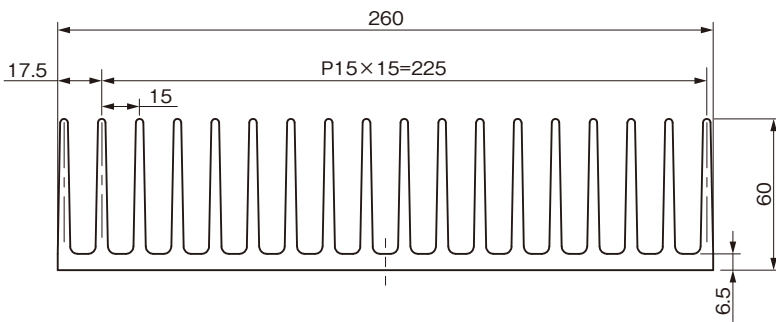

ローレット付

L寸	熱抵抗(°C/W)
L=50	0.76
L=100	0.48
L=150	0.43

— L=50  
— L=100  
— L=150

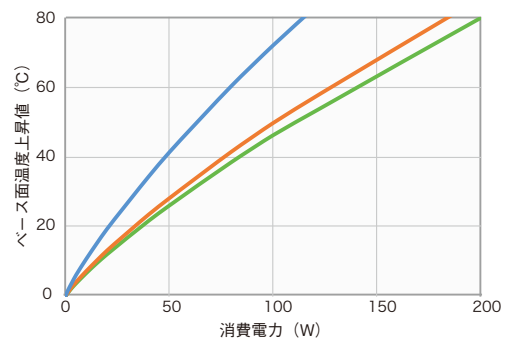

## 61F170

単位重量：12.490kg/m

1:3

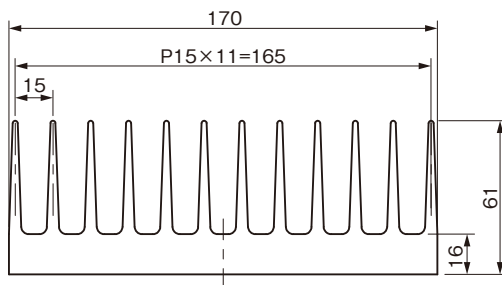

ローレット付

L寸	熱抵抗(°C/W)
L=50	1.23
L=100	0.77
L=150	0.70

— L=50  
— L=100  
— L=150

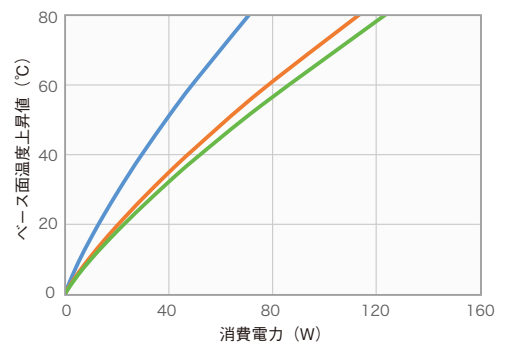

## 64F133

単位重量：6.834kg/m

1:3

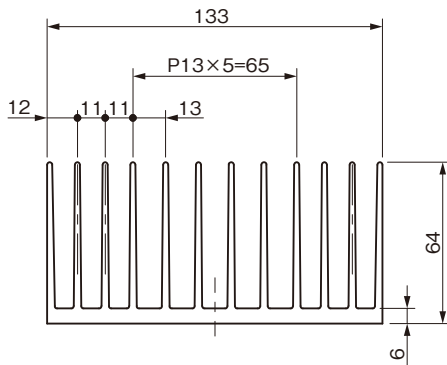

L寸	熱抵抗 (°C/W)
L=50	1.17
L=100	0.73
L=150	0.66

— L=50  
— L=100  
— L=150

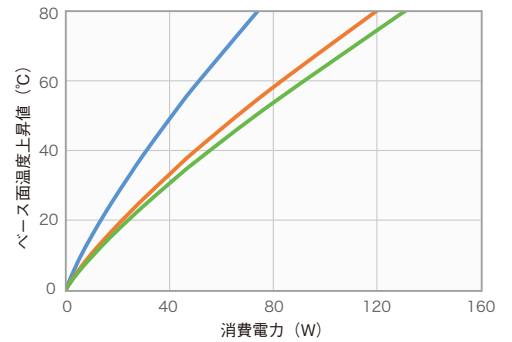

## 67F103

単位重量：6.922kg/m

1:3

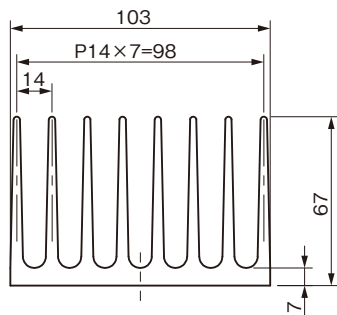

L寸	熱抵抗 (°C/W)
L=50	1.55
L=100	0.96
L=150	0.88

— L=50  
— L=100  
— L=150

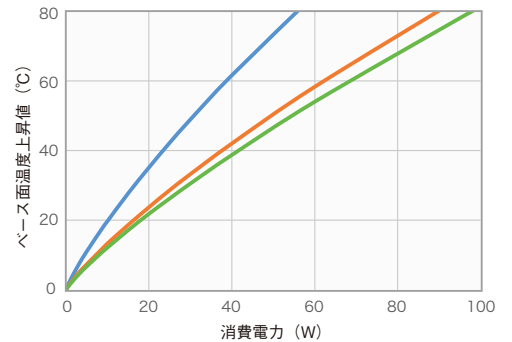

## 70F197

単位重量：12.400kg/m

1:3

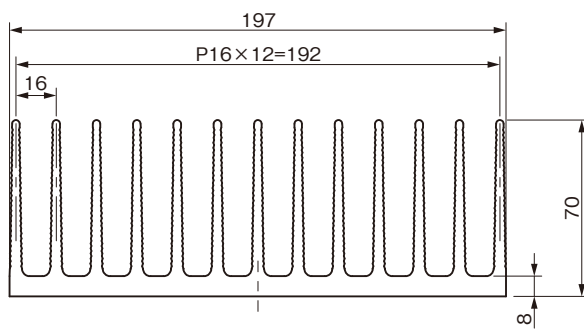

ローレット付

L寸	熱抵抗 (°C/W)
L=50	0.90
L=100	0.57
L=150	0.52

— L=50  
— L=100  
— L=150

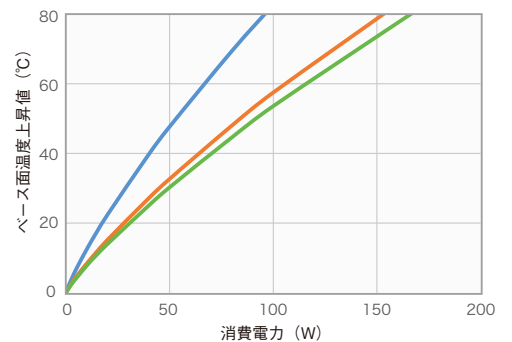

## 77F125

単位重量：8.913kg/m

1:3

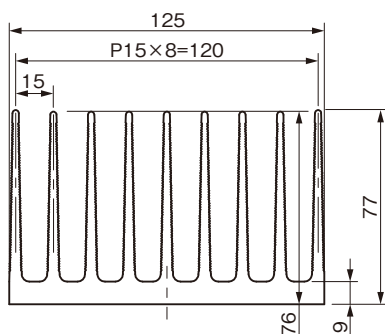

ローレット付

L寸	熱抵抗 (°C/W)
L=50	1.22
L=100	0.77
L=150	0.70

— L=50  
— L=100  
— L=150

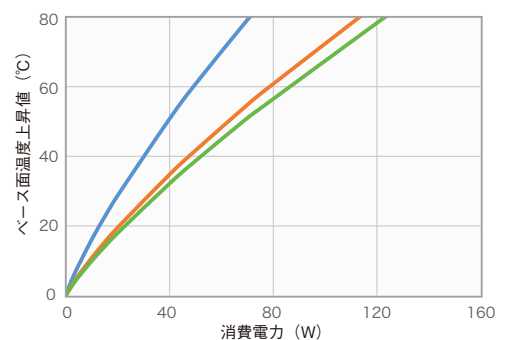

## 78F160

単位重量：10.138kg/m

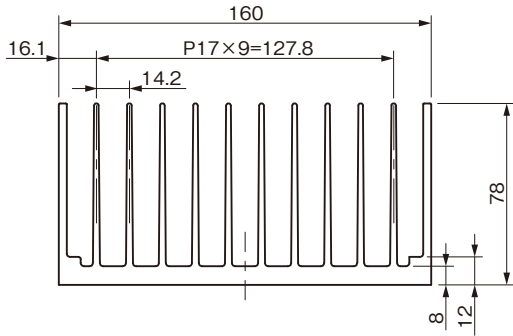

L寸	熱抵抗(°C/W)
L=50	0.94
L=100	0.59
L=150	0.54

— L=50  
— L=100  
— L=150

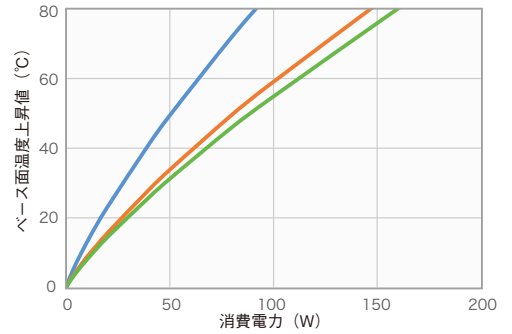

## 90F125

単位重量：13.840kg/m

1:3.25

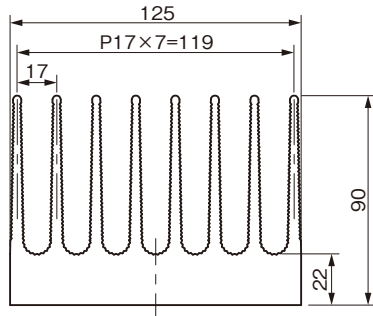

L寸	熱抵抗(°C/W)
L=50	1.22
L=100	0.78
L=150	0.72

— L=50  
— L=100  
— L=150

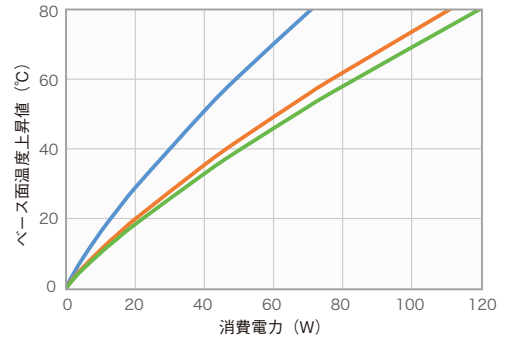

ローレット付

## 90F193

単位重量：21.173kg/m

1:3.25

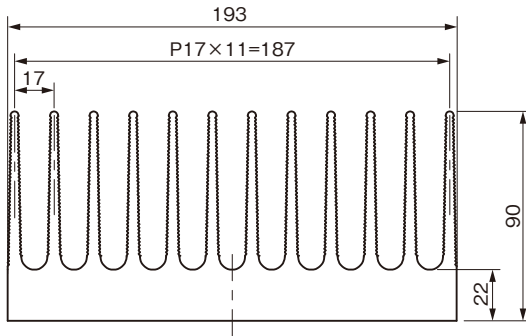

L寸	熱抵抗(°C/W)
L=50	0.85
L=100	0.54
L=150	0.50

— L=50  
— L=100  
— L=150

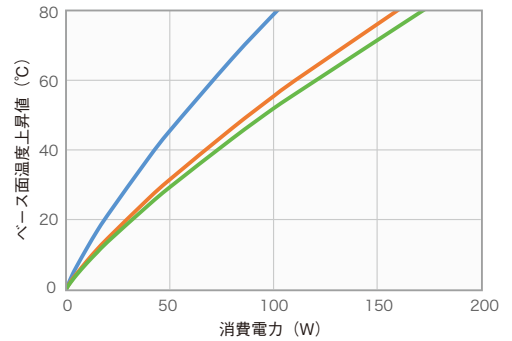

ローレット付

## 90F294

単位重量：24.460kg/m

1:3.25

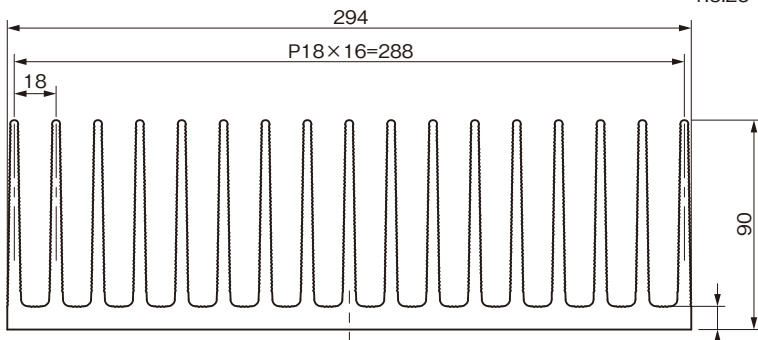

L寸	熱抵抗(°C/W)
L=50	0.55
L=100	0.35
L=150	0.26

— L=50  
— L=100  
— L=150

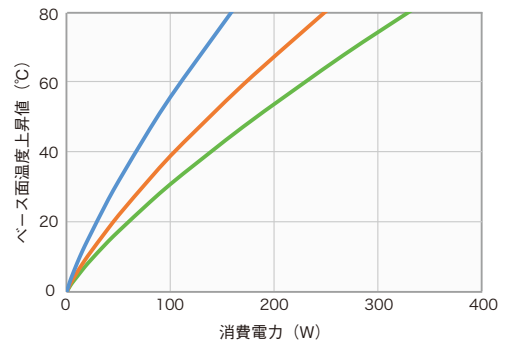

ローレット付